



MESSER

ATTACHMENTS

OPERATOR'S MANUAL

GRAPPLES

All Models

Serial Number 16418-

Manual# 96371 SEPT 2022 ENGLISH

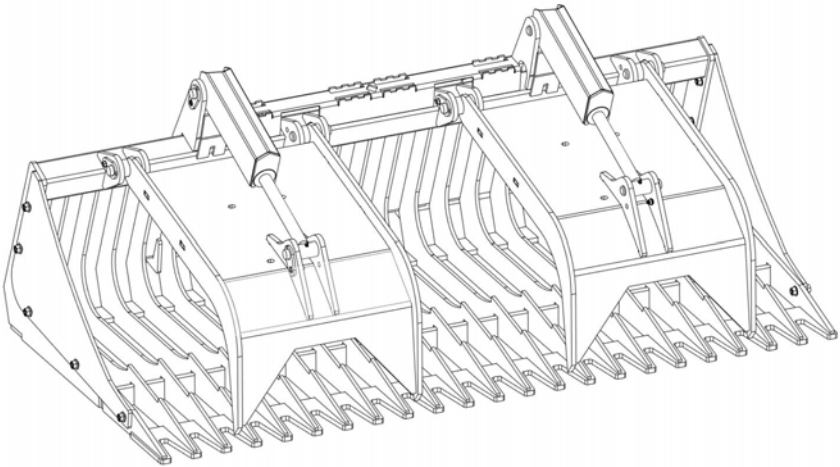

COPYRIGHT © 2022 MESSER
ATTACHMENTS LLC SAUK
CENTRE, MN PRINTED IN USA
ALL RIGHTS RESERVED

Introduction

Using This Manual

Your loader operator's manual contains instructions to safely operate the loader. Anyone who operates a loader with this attachment installed must first read, understand and follow the instructions in the loader operator's manual.

This manual contains instructions to safely operate and service the attachment. Anyone who operates or services the attachment must first read, understand and follow the instructions in this manual.

Additional operating or servicing information for the attachment may be provided online, in video, or in other publications. This additional information does not replace, and is not a substitute for reading and following, the instructions in this manual.

The safety alert symbol is shown in **WARNING** statements to alert users to hazards which could cause death or injury. Carefully read and follow the messages.

IMPORTANT notices alert users to instructions which, if not followed, could result in damage. Carefully read and follow the messages.

There may be times when the attachment and loader shown in this manual may not be your exact model. The model shown will be close enough to your attachment or loader to accurately convey the information.

The most current information available is included in this manual. The publisher may revise this manual at any time and is not required to notify users of revisions.

Replacement Manuals

Be sure to include this operator's manual if you sell or transfer ownership of the attachment.

Contact Messer Attachments LLC for a printed manual, or find a downloadable manual on our website.

Using This Attachment

These attachments are designed for transporting brush and roots, rocks, manure, and other materials.

The attachment is designed for installation on a full-size loader, connected to the loader's front auxiliary hydraulic couplers.

The manufacturer reserves the right to make improvements, and to dis-

Introduction

continue or change specifications, models or design without notice and without incurring obligation.

Loader Compatibility

Confirm your loader's Rated Operating Capacity (ROC in the loader operator's manual. Confirm your attachment's ROC in SPECIFICATIONS in this manual.

Do not install the attachment on the loader if the combined weight of the attachment and attachment load will exceed the loader ROC during operation because this may cause difficulty in controlling the loader or may cause loader damage.

Do not exceed the attachment's ROC because this may damage the attachment.

Attachment compatibility with your loader should be confirmed before the initial purchase. If you receive the attachment as part of a later resale or transfer of ownership, contact the manufacturer to confirm the attachment is designed to be used with your loader before you install the attachment.

Product Misuse

Product misuse can cause accidents, injury and death.

The manufacturer of the attachment is not responsible for any harm or injury resulting from product misuse.

Product misuse includes operating or servicing the attachment without following the instructions in this manual and in the loader manuals, using the attachment in any way for which it was not designed, neglecting to confirm loader compatibility, and modifying the attachment.

Modifications

Do not modify the attachment in any way.

Manufacturer Contact

Call Messer Attachments LLC at (833) 352-3477, or see us at www.messerattach.com.

Product Identification

Identification Numbers

Record your product information to provide when you contact the dealer or manufacturer.

Brush and Root Grapple

Manure Fork Grapple

Material Bucket Grapple

Rock Bucket Grapple

Serial Number 16418-

Serial Number Location



Purchase Date	
Dealer	
Dealer Phone	
Model	
Serial #	

Specifications

Brush and Root Grapple	
Model: 72 Inch	BG72
Overall Width x Height	183 x 76 cm (72 x 30 in.)
Weight	342 kg (755 lb.)

Model: 78 Inch	BG78
Overall Width x Height	201 x 76 cm (79 x 30 in.)
Weight	358 kg (790 lb.)

Model: 85 Inch	BG85
Overall Width x Height	216 x 76 cm (85 x 30 in.)
Weight	370 kg (815 lb.)

Model: All	BG72, BG78, BG85
Depth	112 cm (44 in.)
Teeth Thickness	1/2 in. Grade 50
Space Between Teeth	15 cm (6 in.)
Grapple Jaw Opening	107 cm (42 in.)
Cylinders (2)	2 in. x 8 in. 3500 psi welded cross tube

Manure Fork Grapple	
Model: 60 Inch	MFG60
Overall Width x Height	152 x 79 cm (60 x 31 in.)
Number of Tines	8
Weight	318 kg (700 lb.)

Model: 68 Inch	MFG68
Overall Width x Height	173 x 79 cm (68 x 31 in.)
Number of Tines	9
Weight	340 kg (750 lb.)

Specifications

Manure Fork Grapple	
Model: 75 Inch	MFG75
Overall Width x Height	191 x 79 cm (75 x 31 in.)
Number of Tines	10
Weight	361 kg (795 lb.)

Model: 84 Inch	MFG84
Overall Width x Height	213 x 79 cm (84 x 31 in.)
Number of Tines	11
Weight	381 kg (840 lb.)

Model: All	MFG60, MFG68, MFG75, MFG84
Depth	97 cm (38 in.)
Grapple Jaw Opening	107 cm (42 in.)
Tines Center to Center	20 cm (8 in.)
Cylinders (2)	2 in. x 8 in. 3500 psi welded cross tube

Material Bucket Grapple	
Model: 66 Inch	MBG66
Overall Width x Height	191 x 79 cm (67 x 31 in.)
Weight	361 kg (925 lb.)
Capacity/Struck	15.9 cubic ft.
Capacity/Heaped	19.1 cubic ft.

Model: 72 Inch	MBG72
Overall Width x Height	185 x 79 cm (73 x 31 in.)
Weight	435 kg (960 lb.)
Capacity/Struck	17.3 cubic ft.
Capacity/Heaped	20.8 cubic ft.

Specifications

Material Bucket Grapple	
Model: 78 Inch	MBG78
Overall Width x Height	201 x 79 cm (79 x 31 in.)
Weight	454 kg (1000 lb.)
Capacity/Struck	18.8 cubic ft.
Capacity/Heaped	22.6 cubic ft.
<hr/>	
Model: 84 Inch	MBG84
Overall Width x Height	216 x 79 cm (85 x 31 in.)
Weight	470 kg (1035 lb.)
Capacity/Struck	20.2 cubic ft.
Capacity/Heaped	24.2 cubic ft.
<hr/>	
Model: All	MBG66, MBG72, MBG78, MBG84
Depth	97 cm (38 in.)
Grapple Jaw Opening	112 cm (44 in.)
Cylinders (2)	2 in. x 8 in. 3500 psi welded cross tube
<hr/>	
Rock Bucket Grapple	
Model: 61 Inch	RBG61
Overall Width x Height	155 x 79 cm (61 x 30 in.)
Weight	390 kg (860 lb.)
<hr/>	
Model: 68 Inch	RBG68
Overall Width x Height	175 x 79 cm (69 x 30 in.)
Weight	397 kg (875 lb.)
<hr/>	
Model: 75 Inch	RBG75
Overall Width x Height	191 x 79 cm (75 x 30 in.)
Weight	424 kg (935 lb.)

Specifications

Rock Bucket Grapple	
Model: 82 Inch	RBG82
Overall Width x Height	208 x 79 cm (82 x 30 in.)
Weight	445 kg (980 lb.)
Model: 88 Inch	RBG88
Overall Width x Height	226 x 79 cm (89 x 30 in.)
Weight	465 kg (1025 lb.)
Model: All	RBG61, RBG68, RBG75, RBG82, RBG88
Depth	107 cm (42 in.)
Teeth Thickness	3/8 in. Grade 50
Space Between Teeth	7.6 cm (3 in.)
Grapple Jaw Opening	107 cm (42 in.)
Cylinders (2)	2 in. x 8 in. 3500 psi welded cross tube

Safety Decals

Decal Locations



Location	Description	Part Number
A	Stand Clear Decal	96028
B	Warning Decal	96117

STAND CLEAR DECAL 96028



STAND CLEAR WHILE IN OPERATION

WARNING DECAL 96117



HIGH PRESSURE FLUID HAZARD

To prevent serious injury or death:

- Relieve pressure on system before repairing, adjusting or disconnecting.
- Wear proper hand and eye protection when searching for leaks. Use wood or cardboard instead of hands.
- Keep all components in good repair.

Safety

Wear Protective Equipment

- Wear gloves to protect hands from burns if hydraulic couplers become hot during operation.
- Never wear sandals or other light footwear when operating or servicing the attachment. Wear protective footwear when handling blades or heavy parts.
- Do not wear loose fitting clothing which may become entangled when operating or servicing the attachment.

Parking Safely

1. Follow the instructions in the loader operator's manual to park the loader safely.
2. Fully lower the attachment to level ground.
3. Stop the loader engine and remove the key from the switch.
4. Do not leave the loader operator seat until the engine and all other moving loader and attachment parts have stopped.
5. Follow the instructions in the loader operator's manual to exit the loader safely. Use the attachment step area if one is provided.

Operating Attachments Safely

- Always be aware of the weight of any loads you are transporting with an attachment. The weight of any load must not exceed the attachment's Rated Operating Capacity. The weight of the attachment combined with the attachment load must not exceed the loader's Rated Operating Capacity.
- Do not allow anyone to operate the attachment unless they have first read and understood the loader and the attachment operator's manuals.
- Do not allow anyone to operate the attachment unless they have first read and understood the safety and warning decals on the loader and on the attachment.
- The attachment owner is responsible for training others to safely operate the attachment, and is responsible for any injuries or harm which occurs while the attachment is being operated.
- If an area to step on the attachment has been provided, be sure to use it when entering and exiting the loader.

Safety

- Before operating, replace any worn or damaged safety decals.
- Before operating, thoroughly inspect the attachment to be sure all hardware (bolts, nuts, etc.) is installed and tightened.
- Before operating, thoroughly inspect the attachment to be sure it is in working order. If the attachment is damaged or otherwise not in working order, do not operate until it has been repaired by a qualified technician.
- Before raising or lowering the attachment be sure the area is clear of bystanders.
- Do not operate the loader or the attachment if you are under the influence of alcohol, drugs, or medications which may cause drowsiness.
- Do not allow children to operate the loader or the attachment.
- Do not allow anyone who has not been trained to operate the loader or the attachment.
- Never allow riders on the attachment.
- Keep hands, feet or other objects away from underneath the attachment while operating.
- Fully lower the attachment to level ground when you are done operating.
- Never leave the attachment unattended while in a raised position.
- When transporting the attachment installed on the loader, travel at a slower speed to maintain control.

Using Grapples Safely

- Keep the load centered on the attachment during travel.
- The hooks on the attachment can crush or pinch body parts. Keep bystanders and animals away during operation.
- Confirm the attachment is completely under the load and the grapples are closed securing the load before lifting it.
- Do not attempt to lift a load with a height greater than the distance of the fully raised hooks. The hooks must securely “grip” the load before lifting and transporting the load.

Safety

Servicing Safely

- Disconnect the attachment hydraulic hoses from the loader before servicing. Do not service the attachment when the hydraulic hoses are installed on the loader.
- Remove the attachment from the loader before servicing when instructed to do so in this manual.
- Do not allow anyone to service the attachment unless they have first read and understood the loader and the attachment operator's or service manuals.
- Do not allow anyone to service the attachment unless they have first read and understood the safety and warning decals on the loader and on the attachment.
- The attachment owner is responsible for training others to safely service the attachment, and is responsible for any injuries or harm which occurs while the attachment is being serviced.
- Before inspecting or servicing the attachment, follow the Parking Safely instructions in this manual and disconnect the attachment hydraulic hoses from the loader.
- Always securely block the attachment to prevent accidental release of the lifting mechanism when inspecting or servicing the attachment.

Hydraulic Fluid Safety

- Read and understand the hydraulic safety information in the loader operator's manual before operating or servicing the attachment.
- Use cardboard or a board when you check for a leak.
- Fluid in hydraulic hoses is under extreme pressure. If fluid is injected into your skin seek medical treatment immediately.
- Do not handle any hydraulic components until pressure has been relieved from the system.
- Disconnect the attachment hydraulic hoses from the loader before inspection or service.
- Inspect attachment hydraulic hoses and hose shields for damage or wear before attaching to the loader.

Safety

Safety Decals

Safety decals may be installed on the attachment to warn users of safety hazards:

- **DANGER** decals provide warnings about hazardous situations which will result in death or serious injury if not avoided.
- **WARNING** decals provide warnings about hazardous situations which could result in death or serious injury if not avoided.
- **CAUTION** decals provide warnings about hazardous situations which could result in injury if not avoided.

Read and understand all safety decals before operating or servicing the attachment.

See the Decal Locations illustration in this manual to confirm where decals are installed on the attachment.

Safety decals which are missing, worn or faded must be replaced. Replacement safety decal part numbers are included in this manual. Contact the attachment manufacturer for replacement decals.

Installing and Removing

Preparing for Installation

1. Check the loader and attachment hydraulic couplers to be sure the surfaces are clean before connecting.
2. Inspect the couplers for damage or wear and replace if needed for proper connection.

Installing the Attachment

1. Follow the instructions in the loader operator's manual to install the attachment and exit the operator station safely.
2. Fully lower the loader lift arms.



WARNING
AVOID INJURY!

Loader attaching plate levers which are operated manually may have spring tensioning. Firmly grasp the levers and move the levers slowly.

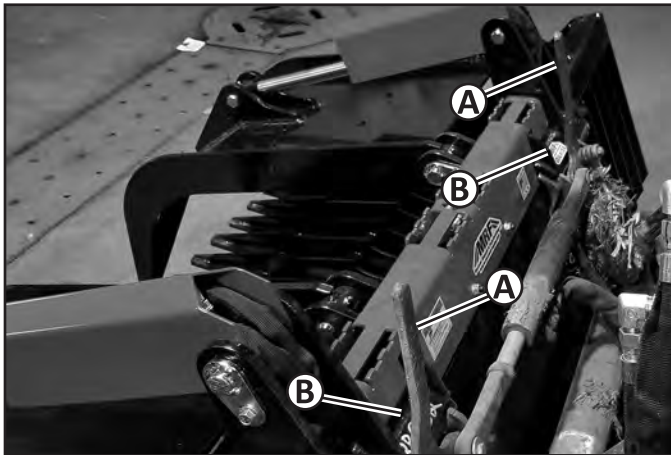

3. Move the loader attaching plate levers (A) to the unlocked (up) position either manually or by using the loader controls.

Installing and Removing



IMPORTANT

AVOID DAMAGE!

Attaching plate levers may be damaged if they strike the attachment. Be sure the attaching plate levers do not hit the attachment during installation.

4. Tilt the loader attaching plate forward, and drive the loader forward until the top edge of the loader attaching plate is under the top flange (B) of the attachment mounting frame.
5. Raise the loader lift arms slightly until the attaching plate is fully seated under the top flange.
6. Tilt the attaching plate backward to raise the front of the attachment.

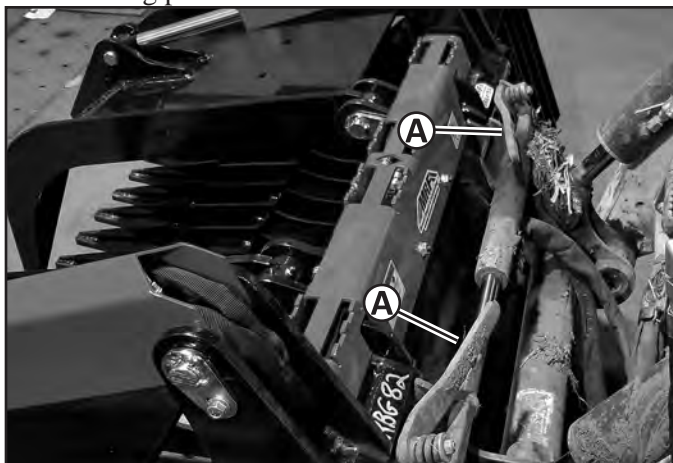

7. Move the loader attaching plate levers (A) to the locked (fully down) position either manually or by using the loader controls.
8. Park the loader. (See Parking Safely in this manual.)



IMPORTANT

AVOID DAMAGE!

The attachment may come off the loader if it is not secured to the attaching plate. The attaching plate pins or wedges must be extended into the attachment with the levers fully down.

Installing and Removing



Picture Note: Wedge on left side shown. Check the wedges or pins on both sides of the attachment.

9. Check to be sure the loader attaching plate pins or wedges (C) extended into the holes in the bottom of the attachment mounting frame. If not, move the loader attaching plate levers to the unlocked (up) position and repeat installation.

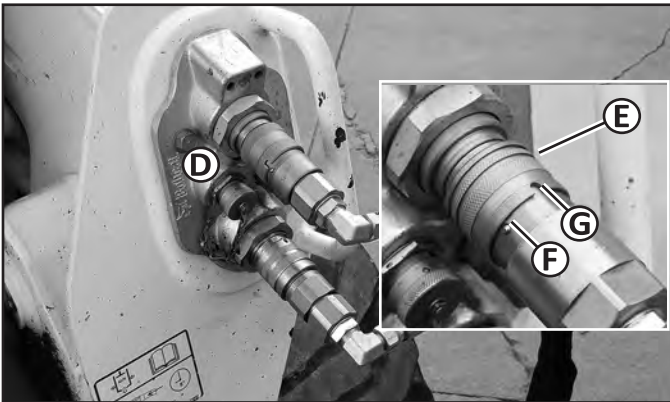

10. Connect the attachment hydraulic hoses to the loader's front auxiliary couplers (D).
 - a. Install the male couplers into the female couplers and pull or push the sleeves (E) to be sure they are locked into place.
 - b. Rotate the coupler sleeves as shown so the ball (F) is outside the groove (G) to prevent the coupler disconnecting (Some sleeves may not have this locking mechanism).

Installing and Removing

Removing the Attachment

1. Follow the instructions in the loader operator's manual to remove the attachment and exit the operator station safely.
2. Fully lower the loader lift arms and the attachment to level ground.
3. Follow instructions in the loader operator's manual to relieve hydraulic pressure in the front auxiliary hydraulic coupler lines.
4. Stop the loader engine.

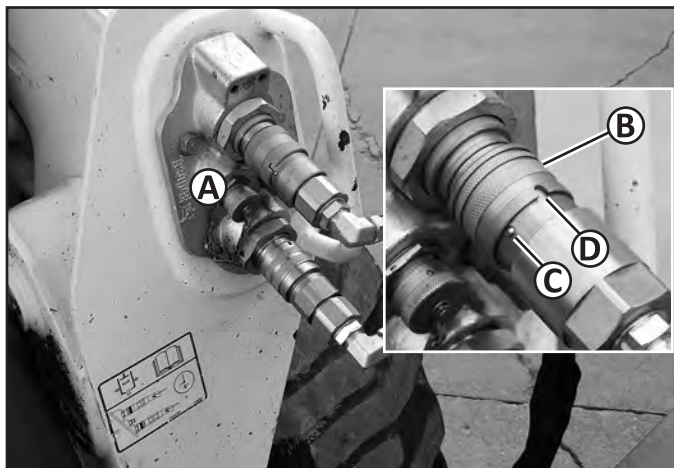

5. Disconnect the attachment hydraulic hoses from the loader's front auxiliary couplers (A).
 - a. Rotate the coupler sleeves (B) so the ball (C) is aligned with the groove (D) to allow the coupler to disconnect (Some sleeves may not have this locking mechanism).
 - b. Grasp and push or pull the sleeves to disconnect the couplers.
6. Install protective caps on the couplers if they are provided.

Installing and Removing

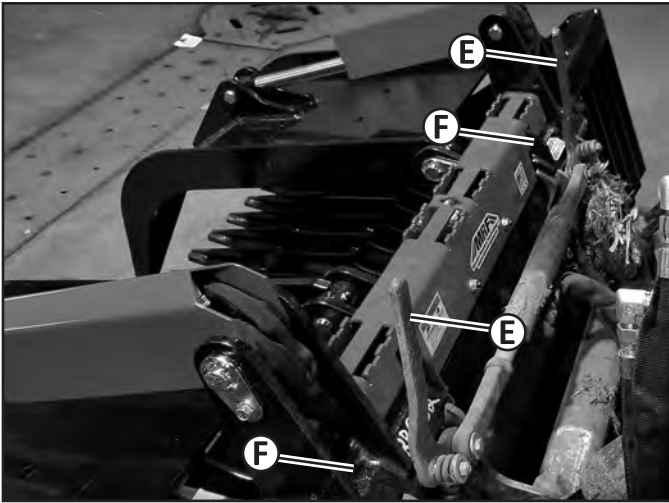

WARNING

AVOID INJURY!

Loader attaching plate levers which are operated manually may have spring tensioning. Firmly grasp the levers and move the levers slowly.

7. Move the loader attaching plate levers (E) to the unlocked (up) position as shown either manually or by using the loader controls.
8. Tilt the loader attaching plate forward slightly and drive the loader backward until the top edge of the attaching plate clears the top flange (F) of the attachment mounting frame.

Operating

Pre-Operation Inspection

Before starting operation, inspect the area you will be clearing and inspect the attachment.

Confirm Loader Compatibility

It may be possible for the hooks on the grapple to cause damage when they are fully raised if they contact the lift arms on some loader models. Before beginning operation fully raise the hooks to confirm whether they may come into contact with the loader lift arms. If they do, avoid fully raising the hooks during operation to avoid machine damage.

Inspect the Work Area

1. Confirm the area is clear of bystanders including animals. Establish a safety zone by keeping bystanders and animals beyond a 100 foot radius around the attachment when operating.

Inspect the Attachment

1. Inspect the attachment to be sure it is in working order. If the attachment is damaged or not in working order, do not operate until it has been repaired by a qualified technician.

Description

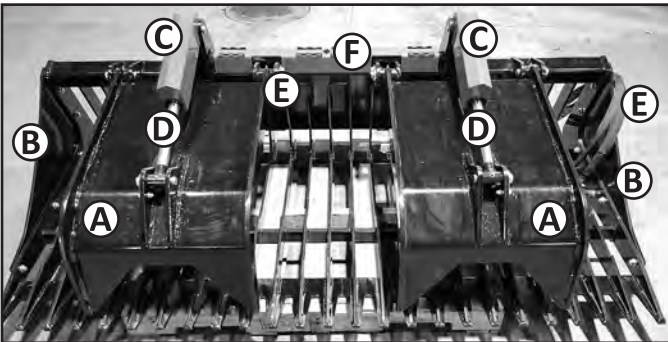

A - Hook

B - Removable Side

C - Cylinder Guard

D - Hydraulic Cylinder

E - Hydraulic Hoses

F - Step Area

Theory of Operation

The Grapple hydraulic hoses are connected to the loader front auxiliary hydraulic couplers. The loader's hydraulic controls are used to extend and retract the hydraulic cylinders, which raise and lower the hooks to hold the material in the attachment.

Operating

Operation

1. Follow the instructions in the Installing and Removing section to install the attachment.
2. Park the loader. (See Parking Safely in this manual.)
3. Perform the pre-operation inspection.

Loading the Material

1. Confirm the material to be lifted will not exceed the loader's Rated Operating Capacity. Reduce the amount of material and load weight if needed.



2. Use the loader hydraulic controls to fully raise the hooks (A).
3. Drive forward until the material reaches the back of the attachment.
4. Use the loader hydraulic controls to lower the hooks until you have a firm “grip” on the material.
5. Tilt the attachment back.
6. Raise the attachment from the ground only as far as needed to travel with the load.

Operating

Traveling With the Material

1. Keep the attachment tilted back and raised from the ground only as far as needed for travel.
2. Travel slowly, and watch for any bystanders or objects in your travel area.
3. Stop travel before raising or lowering the attachment.

Releasing the Material

1. Stop travel.
2. Raise the attachment and move forward slowly.
3. Tilt the attachment downward as you raise the hooks to release the material.
4. Check behind for bystanders or objects in your travel area and back slowly.
5. Fully lower the attachment and the hooks.

Transporting the Attachment

On the Loader

Check to be sure the attachment is correctly installed on the loader before hauling the loader on a trailer or truck. Follow all loader, truck or trailer operator's manual instructions to safely haul the loader.

Hauling the Attachment

Follow all truck or trailer operator's manual instructions to securely fasten the attachment to the truck or trailer with straps or chains.

Servicing

Service Intervals

Every 8 hours or daily:

- Grease the mount pins.
- Inspect the attachment and hoses for damage and wear. Replace parts as needed.
- Check and tighten all hardware.

Lubrication

Recommended Grease

Standard Lithium

Lubricating the Mount Pins

1. Use the loader hydraulic controls to fully lower the hooks.
2. Park the loader. (See Parking Safely in this manual.)



3. Disconnect the attachment hydraulic hoses from the loader.

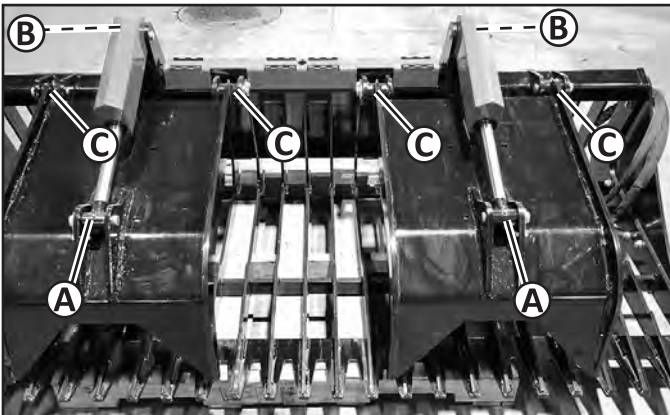

4. Lubricate the two grease fittings (A) on the cylinder rod ends until grease appears in the joints.
5. Lubricate the two grease fitting (B) on the cylinder base ends until

Servicing

grease appears in the joints.

6. Lubricate the four grease fittings (C) on the hook mount pins until grease appears in the joints.

Removing the Step Area

1. Use the loader hydraulic controls to fully lower the hooks.



2. Remove the attachment from the loader.
3. Park the loader. (See Parking Safely in this manual.)

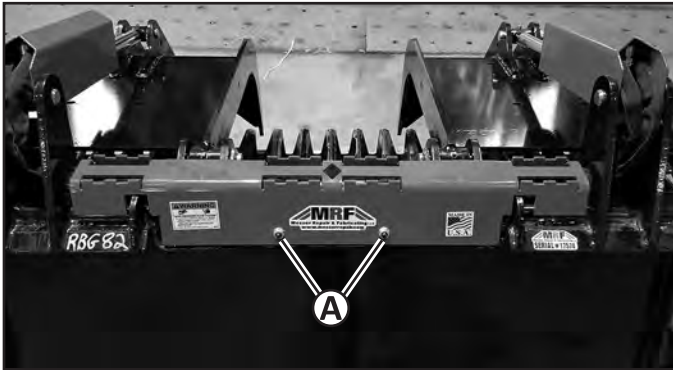

4. Remove the two nuts (A) attaching the step area to the attachment.
5. Remove the step area to access the hydraulic hoses.

Removing the Cylinder Guards

1. Use the loader hydraulic controls to fully lower the hooks.



2. Remove the attachment from the loader.

Servicing

3. Park the loader. (See Parking Safely in this manual.)

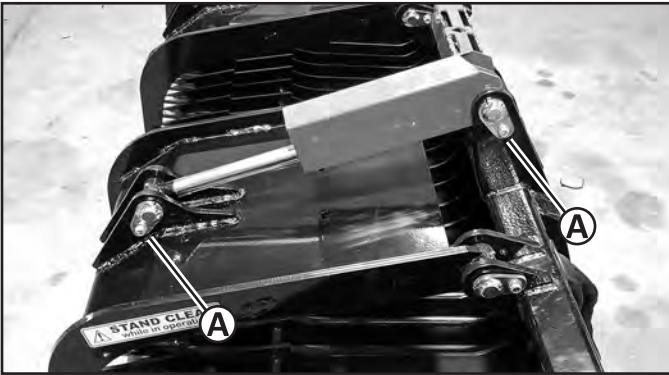

4. Remove the bolts (A) and both mount pin weldments attaching the cylinder to the attachment.

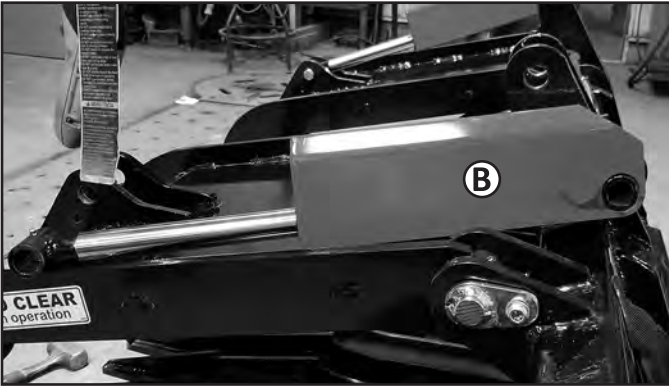

5. Remove the cylinder with the guard (B).



6. Remove the guard from the cylinder (C).

Servicing

Replacing the Hydraulic Hoses

1. Use the loader hydraulic controls to fully lower the hooks.



2. Remove the attachment from the loader.
3. Park the loader. (See Parking Safely in this manual.)
4. Remove the step area. (See Removing the Step Area.)

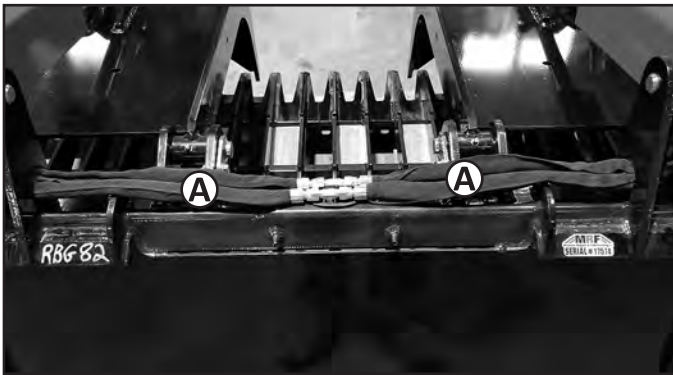

5. Disconnect the hydraulic hose (A).
6. Remove the cylinder guard. (See Removing the Cylinder Guards.)
7. Disconnect and remove the hydraulic hose from the cylinder.



Servicing

8. Remove the hoses from the retainer (B).
9. Connect the new hose to the cylinder.
10. Connect the new hose under the step area.
11. Install the cylinder with the guard.
12. Install the hoses in the retainer.

Replacing the Hydraulic Cylinders

1. Use the loader hydraulic controls to fully lower the hooks.



2. Remove the attachment from the loader.
3. Park the loader. (See Parking Safely in this manual.)
4. Remove the cylinder guard. (See Removing the Cylinder Guards.)
5. Disconnect and remove the hydraulic hose from the cylinder.
6. Install the hydraulic hose on the new cylinder.
7. Install the new cylinder with the cylinder guard.

Removing the Grapple Sides (If Equipped)

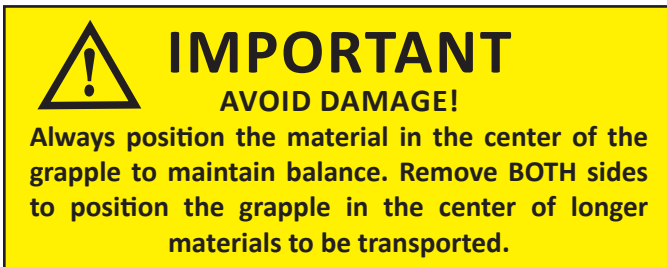

1. Use the loader hydraulic controls to fully lower the hooks.
2. Park the loader. (See Parking Safely in this manual.)

Servicing

 **WARNING**
AVOID INJURY!
Disconnect the attachment hydraulic hoses from the loader before servicing.

3. Disconnect the attachment hydraulic hoses from the loader.

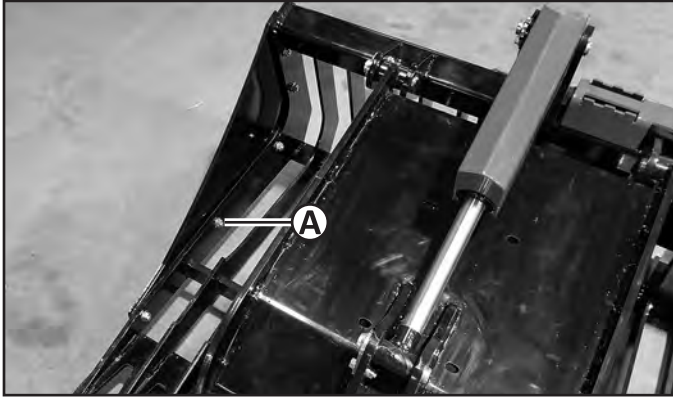

4. Remove the nuts (A), washers and bolts attaching the sides to the attachment.
5. Install the hardware in the side if it will be stored.

Replacing the Hooks

1. Use the loader hydraulic controls to fully lower the hooks.

 **WARNING**
AVOID INJURY!
Remove the attachment from the loader before servicing.

2. Remove the attachment from the loader.
3. Park the loader. (See Parking Safely in this manual.)

Servicing

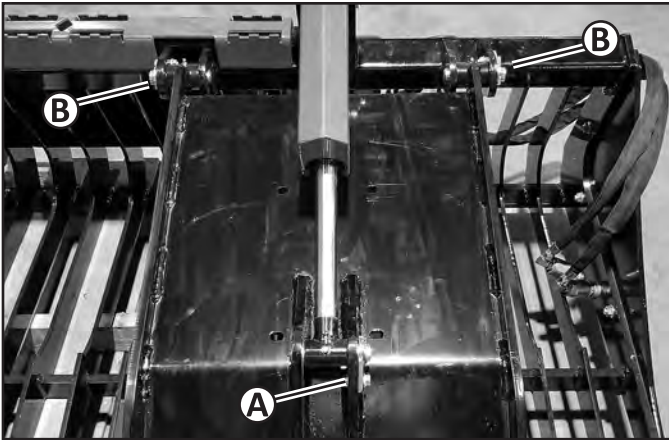

4. Remove the nut (A), bolt and mount pin weldment from the rod end of the cylinder.
5. Remove the nuts, bolts and two pin weldments (B) from the hook.
6. Attach the new hook with the two pin weldments, bolts and nuts.
7. Attach the hydraulic cylinder with mount pin weldment, bolt and nut.

Installing the Optional Rod End Cylinder Guard

1. Use the loader hydraulic controls to fully lower the hooks.
2. Park the loader. (See Parking Safely in this manual.)



WARNING
AVOID INJURY!
Disconnect the attachment hydraulic hoses from
the loader before servicing.

3. Disconnect the attachment hydraulic hoses from the loader.

Servicing

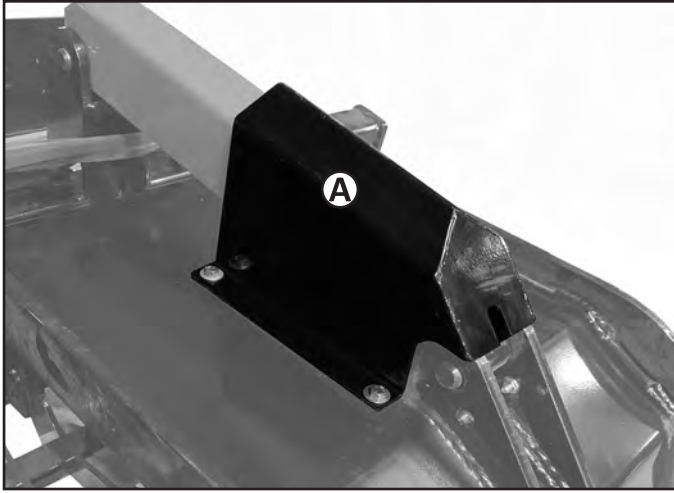

4. Install the guard (A) over the cylinder rod end with four bolts, washers and nuts.

Troubleshooting

Cause	Action
Hooks won't raise or lower.	<ol style="list-style-type: none">1. Check to be sure the attachment hydraulic couplers are fully connected.2. Check the attachment for hydraulic fluid leaks.3. See the loader operator manual to check loader hydraulic pressure and flow.4. Contact the attachment manufacturer about possible cylinder replacement.

Replacement Parts

Brush and Root Grapple

BG72, BG78, BG85

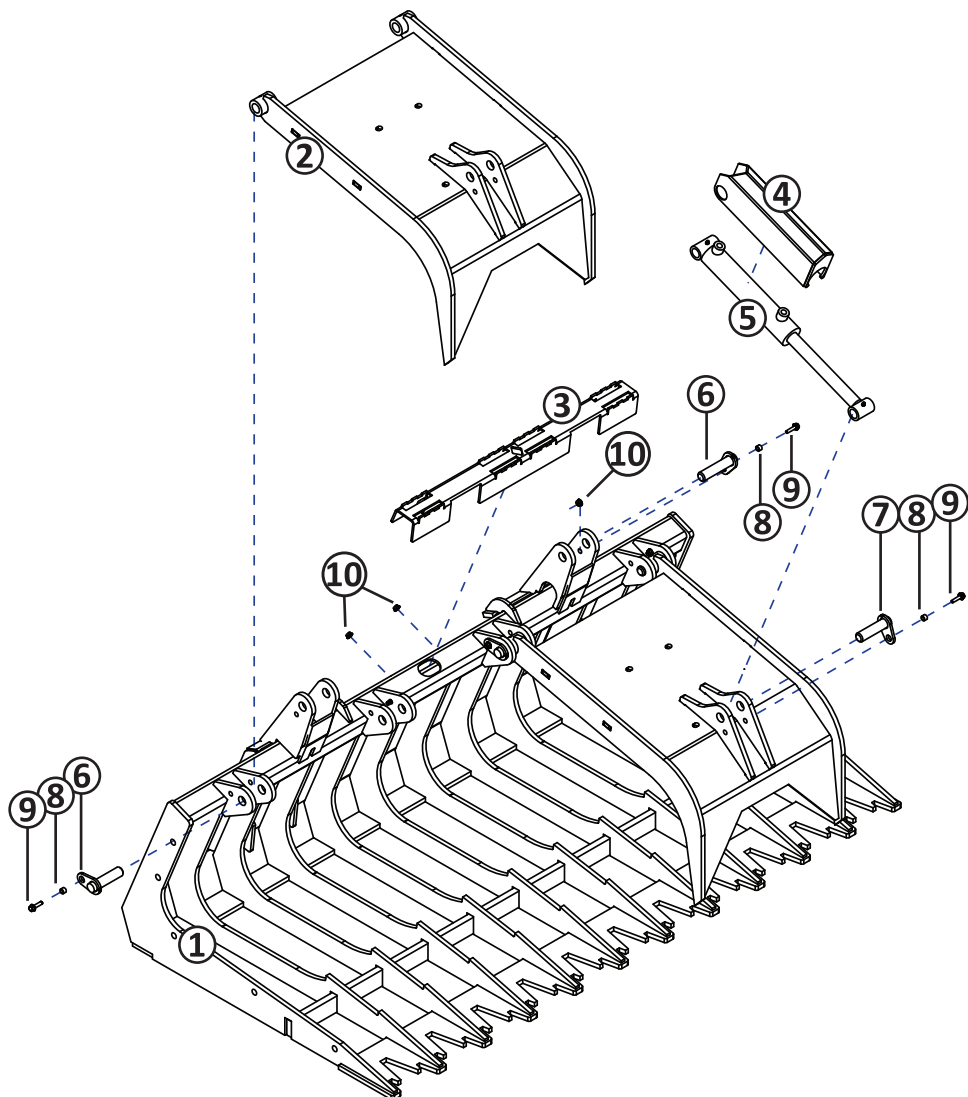

Replacement Parts

Replacement Parts

Contact Messer Attachments LLC for replacement parts. Part numbers may change without notice.

Item	Qty.	Part Number	Part Description
1	1	10399-P	BG72 Body Weldment (10404-P is BG78, 10407-P is BG85)
2	2	10355-P	Hook Weldment
3	1	11126-P	Bolt on Grapple Step
4	2	09523-P	Base End Cylinder Guard
5	2	WCT2X8	Cross Tube Cylinder 2x8, 3500 PSI
6	2	09751	Base End Cylinder Pin Weldment
7	6	09629	Rod End Cylinder Pin Weldment
8	8	11225	Pin Bolt Bushing
9	8	-	Flange Bolt, 3/8 - 16 x 1-1/4
10	10	-	Nut, 3/8 - 16
*	2	-	Sides (Sides and hardware shown in Rock Bucket Grapple parts)

*Part not shown.

Replacement Parts

Manure Fork Grapple

MFG60, MFG68, MFG75, MFG84

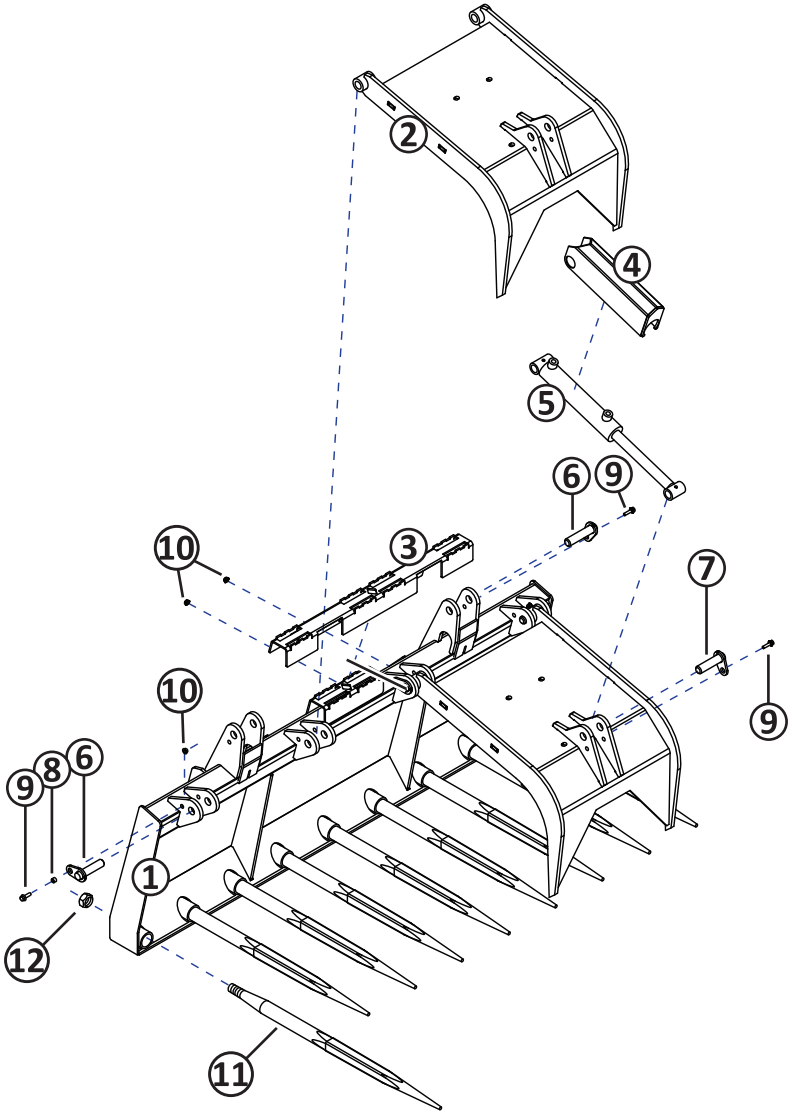

Replacement Parts

Item	Qty.	Part Number	Part Description
1	1	10488-P	MFG60 Body Weldment (10490-P is MFG68, 10492-P is MFG75, 10494-P is MFG84)
2	2	09877-P	Hook Weldment
3	1	11126-P	Bolt on Grapple Step (MFG60 Part Number 05851)
4	2	09523-P	Base End Cylinder Guard
5	2	WCT2X8	Cross Tube Cylinder 2x8, 3500 PSI
6	2	09751	Base End Cylinder Pin Weldment
7	6	09629	Rod End Cylinder Pin Weldment
8	8	11225	Pin Bolt Bushing
9	8	-	Flange Bolt, 3/8 - 16 x 1-1/4
10	10	-	Nut, 3/8 - 16
11	8-11	CON-2-39	Bale Spear, SHW CON-2-39 in. long / 3,000 lb.
12	8-11	-	Bolt

Replacement Parts

Material Bucket Grapple

MBG66, MBG72, MBG78, MBG84

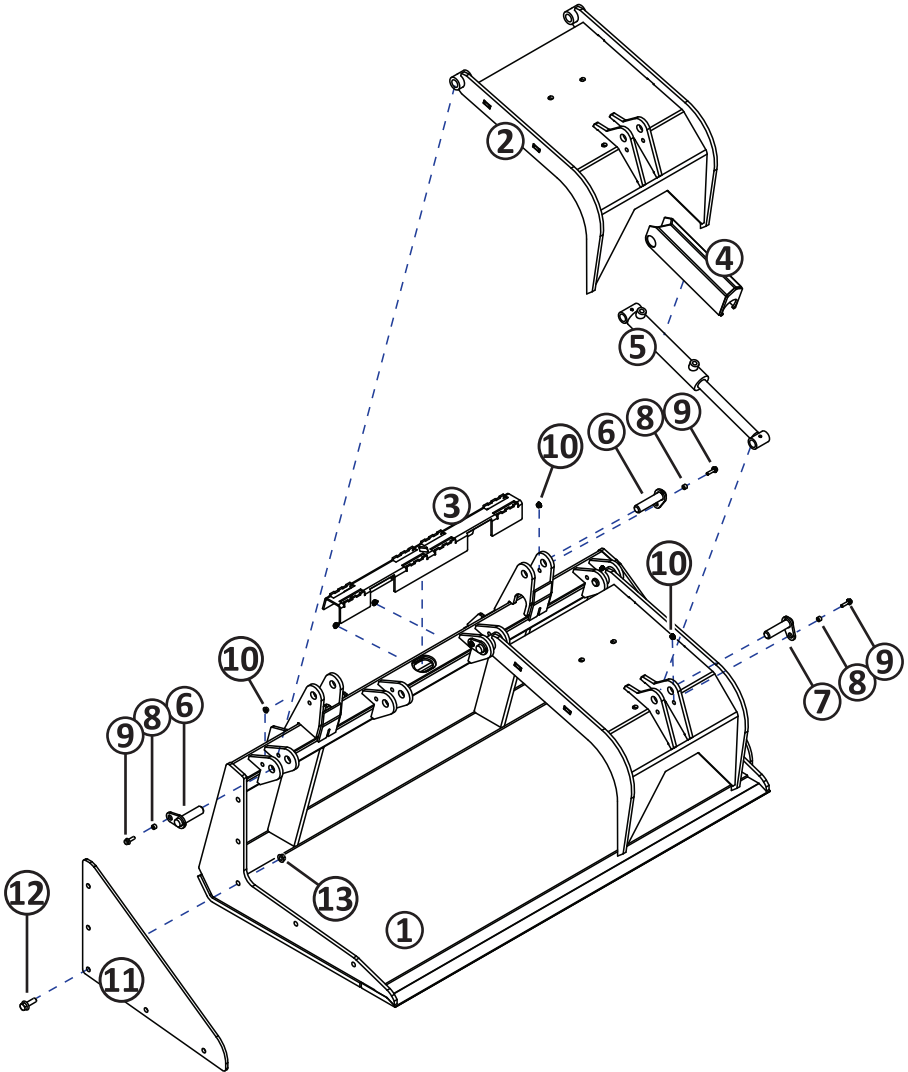

Replacement Parts

Item	Qty.	Part Number	Part Description
1	1	11331-P	MBG66 Body (MBG72 is 09883-P, MBG78 is 11138-P, MBG84 is 11332-P)
2	2	09877-P	Hook Weldment
3	1	11126-P	Bolt on Grapple Step
4	2	09523-P	Cylinder Guard, Base End
5	2	WCT2X8	Cross Tube Cylinder 2 x 8, 3500 PSI
6	2	09751	Cylinder Pin Weldment, Base End
7	6	09629	Cylinder Pin Weldment, Rod End
8	8	11225	Pin Bolt Bushing
9	8	-	Flange Bolt, 3/8 - 16 x 1-1/4
10	10	-	Nut, 3/8 - 16
11	2	05831-P	Sides
12	10	-	Flange Bolt, 1/2 - 13 x 1-1/2
13	10	-	Flange Nut, 1/2 - 13

Replacement Parts

Rock Bucket Grapple

RBG61, RBG68, RBG75, RBG82, RBG88

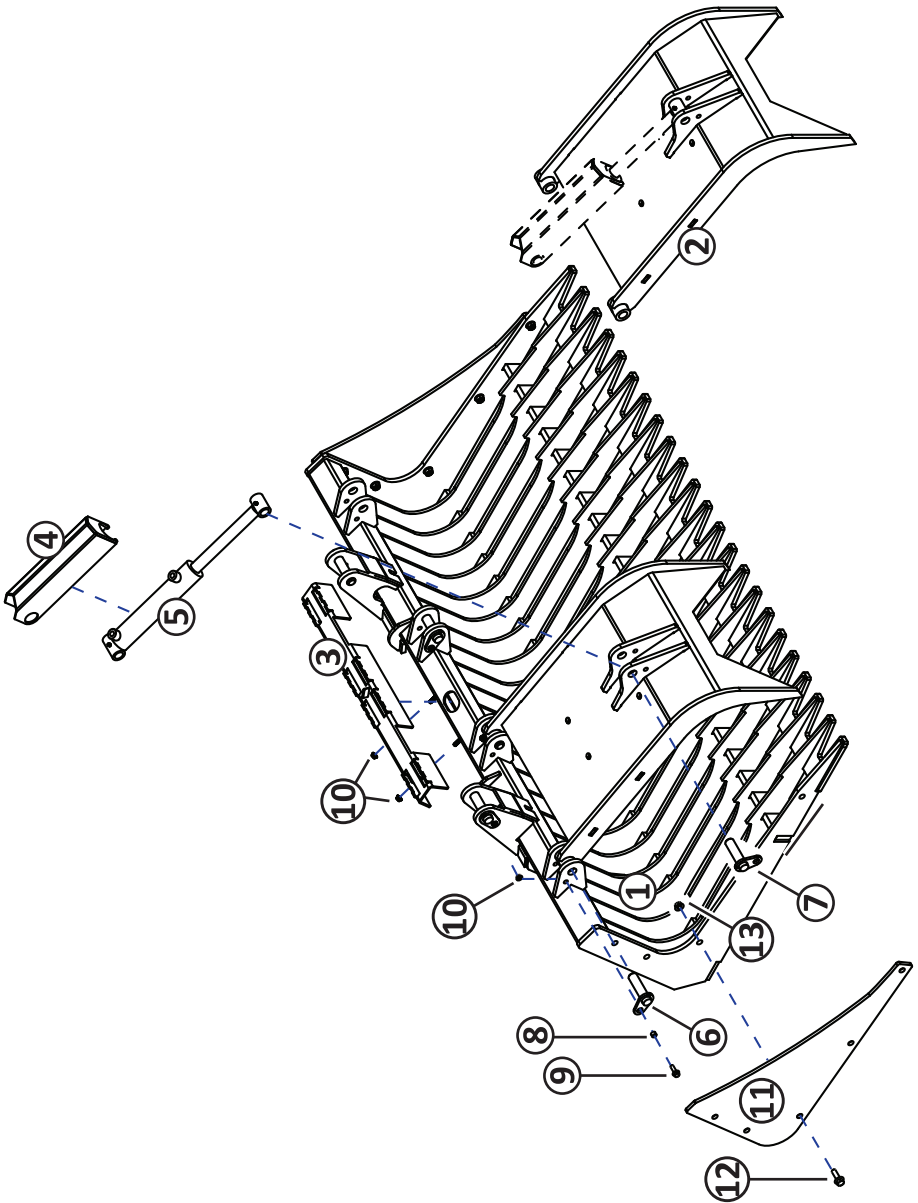

Replacement Parts

Item	Qty.	Part Number	Part Description
1	1	See part description	(RBG61 Body 11898-P, RBG68 Body 10390-P, RBG75 Body 10337-P, RBG82 Body 10393-P, RBG88 Body 10396-P)
2	2	10335-P	Hook Weldment
3	1	11126-P	Bolt on Grapple Step
4	2	09523-P	Cylinder Guard, Base End
5	2	WCT2X8	Cross Tube Cylinder 2 x 8, 3500 PSI
6	2	09751	Cylinder Pin Weldment, Base End
7	6	09629	Cylinder Pin Weldment, Rod End
8	8	11225	Pin Bolt Bushing
9	8	-	Flange Bolt, 3/8 - 16 x 1-1/4
10	10	-	Nut, 3/8 - 16
11	2	05841-P	Sides
12	10	-	Flange Bolt, 1/2 - 13 x 1-1/2
13	10	-	Flange Nut, 1/2 - 13

Replacement Parts

Contact Messer Attachments LLC for replacement parts. Part numbers may change without notice.

Item	Qty.	Part Number	Part Description
*	1	T-2004HS	Hydraulic Clamp, 1/4 in.
*	2	96228	Hose, 1/4, 98 in.
*	2	96229	Hose, 1/4, 39 in.
*	2	96230	Hose, 1/4, 32 in.
*	2	6801-06-08	90 deg. Adapter Fitting
*	4	6801-06-06	90 deg. Adapter Fitting
*	2	2603-06-06-06	Tee Fitting
*	16	96303	U-Channel Push-on Trim for 1/4 Thick Material
*	1	96164	Coupler Assembly, Female, 1/2 ORB-#8, 3/4 -16 SAE
*	1	96165	Nipple Assembly, Male, 1/2 ORB-#8, 3/4 -16 SAE

*Part not shown.

Warranty

MESSER ATTACHMENTS LLC

Limited Warranty and Terms and Conditions of Sale

The following limited warranty, and terms and conditions of sale (the “Limited Warranty”) apply to all equipment, products, parts, and goods (any of the foregoing are referred to herein as “Equipment”) sold by Messer Attachments LLC (“Messer”):

1. **Covers All Equipment.** Each purchase of Equipment by a purchaser is expressly made conditional on purchaser’s assent to the terms and conditions in this Limited Warranty.
2. **Limited Warranty.** Messer warrants that for a period of 24 months from the date of purchase, the Equipment will remain free from defects in material and workmanship under normal use and proper maintenance. The warranty does not cover damage from operating in excess of rated capacities or normal wear and tear. Messer’s obligation under the warranty shall be limited to the repair or replacement (at Messer’s option) of the Equipment. Notwithstanding the foregoing, if the Equipment is used for commercial purposes or is rented or leased out by the purchaser, then, the foregoing warranty shall only be for a period of 180 days and not 24 months.
3. **No Warranty For Equipment Components From Third Parties.** Notwithstanding the limited warranty terms set forth above, MESSER OFFERS NO WARRANTY WHATSOEVER WITH RESPECT TO ANY COMPONENTS OF THE EQUIPMENT MADE OR PROVIDED TO MESSER BY OTHER MANUFACTURERS, PRODUCERS, OR SELLERS (the “Purchased Components”). The sole and exclusive warranty for each the Purchased Components shall be limited to the express written warranty with respect to the Purchased Component as provided by the manufacturer, producer, or seller of such Purchased Component. Messer’s responsibility and liability for the Purchased Components shall be limited to the assignment of the Purchased Components’ express written warranties applicable to the Purchased Components. Purchased Components include, without limitation, the following: axles, tires and rims; trailer hitch components and jacks; hydraulic pumps, motors, cylinders and components; and bales spears, pallet tines, and bucket teeth.
4. **No Other Warranties.** THE FOREGOING REPAIR AND REPLACEMENT OBLIGATIONS IN SECTION 2 ARE IN LIEU OF ALL OTHER WARRANTIES, LIABILITIES AND OBLIGATIONS, INCLUDING ALL WARRANTIES OF MERCHANTABILITY, OF FITNESS FOR A PARTICULAR PURPOSE OR OTHERWISE, EXPRESSED OR IMPLIED IN FACT OR BY LAW, AND STATE MESSER’S ENTIRE AND EXCLUSIVE LIABILITY AND PURCHASER’S EXCLUSIVE REMEDY FOR ANY CLAIM IN CONNECTION WITH THE SALE AND PURCHASE OF EQUIPMENT (AND ALL COMPONENTS THEREOF), THEIR DESIGN, SUITABILITY FOR USE, INSTALLATION OR OPERATIONS.

Warranty

5. Location of Warranty Repairs. All warranty repairs pursuant to this Limited Warranty shall be made at Messer's corporate manufacturing plant, or other location as determined by Messer, at its discretion. Purchaser shall be responsible for and pay for any transportation expenses necessary for Limited Warranty repairs.

6. Limited Warranty Voidable. The limited warranty herein is void and deemed waived if the purchaser fails to give written notice to Messer of any alleged defect under the limited warranty herein within 20 days of its discovery; or (a) purchaser or parties other than Messer or its authorized representatives attempts to remedy or fix the alleged Equipment defects; or (b) purchaser has used the Equipment for purposes it was not intended to be used for; or (c) purchaser has not operated the Equipment in a manner consistent with Messer's instructions for the Equipment; or (d) the Equipment has been modified, altered, abused, or misused; or (e) the Equipment has been damaged pursuant to accident, fire, flood, or other Act of God.

7. No Consequential Damages. IN NO EVENT SHALL MESSER BE LIABLE FOR ANY DIRECT, INDIRECT, SPECIAL OR CONSEQUENTIAL DAMAGES WHATSOEVER, AND MESSER'S LIABILITY, UNDER NO CIRCUMSTANCES, WILL EXCEED THE PRICE PAID FOR THE EQUIPMENT FOR WHICH LIABILITY IS CLAIMED.

8. Governing Law. This contract shall be governed by the laws of the State of Minnesota.

9. Arbitration. Any controversy or claim arising out of or relating to the limited warranty provided herein, or any alleged breach thereof, shall be settled exclusively by arbitration in accordance with the Rules of the American Arbitration Association, and judgment upon the award rendered by the arbitrator may be entered in any court having jurisdiction thereof. The arbitration shall be conducted in Minneapolis, MN, by one arbitrator selected by Messer and Purchaser, or, if they cannot agree, the President of the American Arbitration Association.